

Manual or power operated expanding mandrels

Adapter flanges



Page 170

EM-A

Hand or power operated expanding mandrels

Expanding mandrels
Ø 14.7 - 129.7 mm

- Size 1 - 11
- Large expansibility 1 - 2 mm depending on size
- Flange mounting
- Very rigid design



Page 172

EM-B

Hand or power operated expanding mandrels

Expanding mandrels
Ø 16.0 - 129.5 mm

- Size 0 - 4
- Large expansibility 0.5 - 1.5 mm depending on size
- Flange mounting
- Very rigid design



Page 174

Adapter flanges

ISO-A for
expanding mandrels

- mandrels EM-A and EM-B have cylindrical mounting
- adapters for ISO-A 702/1-DIN 55026 spindle noses



Page 175

Special expanding mandrels



Application/customer's benefit

- For turning, milling, grinding and gear cutting operations
- High accuracy and torque transmission because of fixed arbor
- Axial pull-down by axial movement of the clamping sleeve during actuation
- Quick set-up

Technical features

- Large expansibility 1-2 mm depending on size
- Hand or power operated
- Flange mounting
- Very rigid design
- Tapped holes at the front face to mount axial stops
- Clamping sleeves are also available in vulcanized version

Standard equipment

Basic mandrel with draw bolt for power operation
Mounting bolts

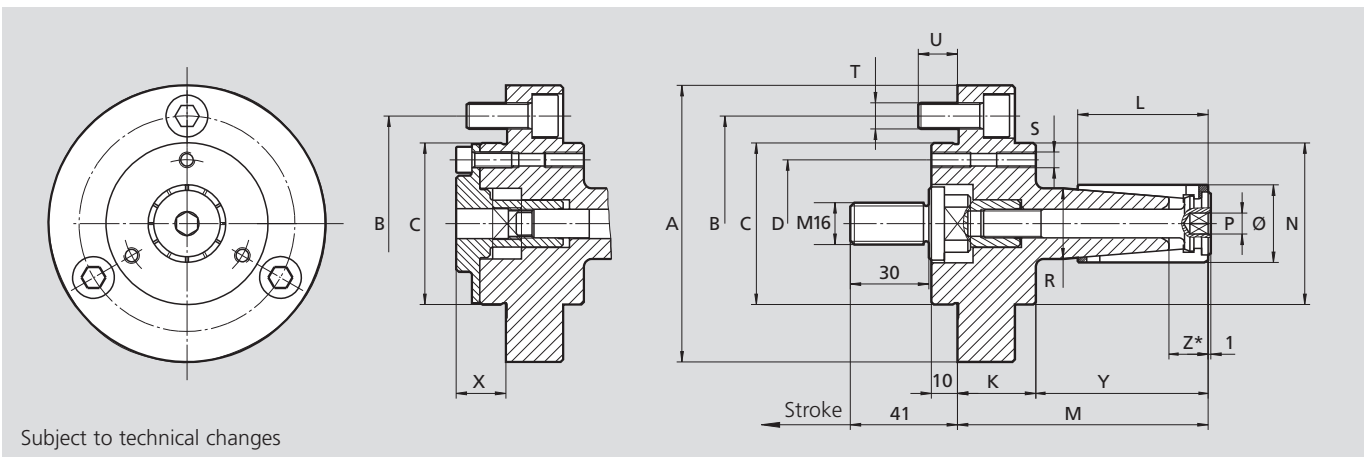

Subject to technical changes

SMW-Autoblok Type	EM-A-1	EM-A-2	EM-A-3	EM-A-4	EM-A-5	EM-A-6	EM-A-7	EM-A-8	EM-A-9	EM-A-10	EM-A-11	
Id.No. (power operated)	68100110	68100210	68100310	68100410	68100510	68100610	68100710	68100810	68100910	68101010	68101110	
Id.No. (manual operated)	68110110	68110210	68110310	68110410	68110510	68110610	68110710	68110810	68110910	68111010	68111110	
A	106	106	106	106	106	106	130	130	130	130	130	
B	82.6	82.6	82.6	82.6	82.6	82.6	104.8	104.8	104.8	104.8	104.8	
C	g5	62	62	62	62	62	86	86	86	86	86	
D	49	49	49	49	49	49	73	73	73	73	73	
K	30	30	30	30	30	30	30	30	30	30	30	
L	35	40	46	50	60	60	80	90	100	122	140	
M	81	86	92	96	106	106	132	142	152	174	195	
N	62	62	62	62	62	62	86	86	86	-	-	
Ø	mm	14.7-19.7	19.7-24.7	24.7-29.7	29.7-34.7	34.7-39.7	39.7-44.7	44.7-54.7	54.7-64.7	64.7-81.7	81.7-101.7	101.7-131.7
P	SW	4	4	6	8	8	8	10	10	10	10	
R	h6	14	19	23	27	31.5	36	42	50	60	73	86
S	(3x120°)	M6	M6	M6	M6	M6	M6	M6	M6	M6	M6	M6
T	(3x120°)	M10	M10	M10	M10	M10	M10	M10	M10	M10	M10	M10
U	15	15	15	15	15	15	15	15	15	17	17	
X	19	19	19	19	19	19	13	13	13	21	21	
Y	51	56	62	66	76	76	102	112	122	144	165	
Z*	12.5	14.5	14.5	15	15.5	16	24	26	26.5	27.5	32	
Insert for manual operation Id.No.	68090110	68090210	68090310	68090410	68090510	68090610	68090710	68090710	68090710	68091010	68091110	
Draw bolt power operation Id.No.	68050110	68050210	68050310	68050410	68050510	68050610	68050710	68050710	68050710	68051010	68051110	

* No clamping only on area Z

Technical data

Stroke	mm	6	6	6	6	6	6	12	12	12	12	12
Max. actuating force	kN	7	9	12	12	15	20	20	20	25	25	30
Max. transmittable torque	Nm	15	35	75	100	120	150	200	250	275	320	500
Actuating cylinder (rec.)		SIN-S 70	SIN-S 70	SIN-S 85	SIN-S 85	SIN-S 85	SIN-S 100	SIN-S 100	SIN-S100	SIN-S-100	SIN-S-100	SIN-S 125

All dimensions in unclamped position

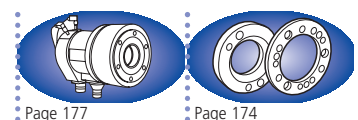

Expanding mandrels Ø 14.7 - 129.7 mm

- size 1 - 11
- large expansibility

EM-A

Expanding mandrel
Manual or power operated

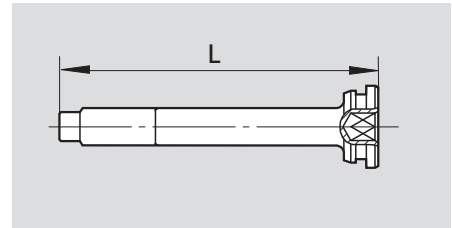
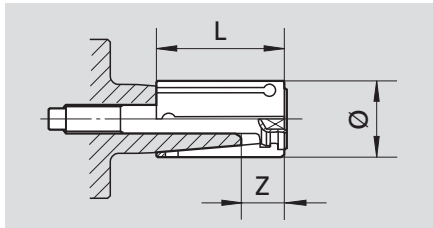
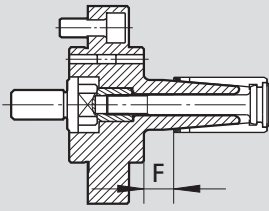

Basic mandrel

Type	Id.No.	F
EM-A-1	68100110	16
EM-A-2	68100210	16
EM-A-3	68100310	16
EM-A-4	68100410	16
EM-A-5	68100510	16
EM-A-6	68100610	16
EM-A-7	68100710	22
EM-A-8	68100810	22
EM-A-9	68100910	22
EM-A-10	68101010	22
EM-A-11	68101110	25

Clamping sleeve complete with actuating screw

Id.No.	Ø	L	Expansibility	Z
68300147	14.7	35	1	12.5
68300157	15.7	35	1	12.5
68300167	16.7	35	1	12.5
68300177	17.7	35	1	12.5
68300187	18.7	35	1	12.5
68300197	19.7	40	1	14.5
68300207	20.7	40	1	14.5
68300217	21.7	40	1	14.5
68300227	22.7	40	1	14.5
68300237	23.7	40	1	14.5
68300247	24.7	46	1	14.5
68300257	25.7	46	1	14.5
68300267	26.7	46	1	14.5
68300277	27.7	46	1	14.5
68300287	28.7	46	1	14.5
68300297	29.7	50	1	15
68300307	30.7	50	1	15
68300317	31.7	50	1	15
68300327	32.7	50	1	15
68300337	33.7	50	1	15
68300347	34.7	60	1	15.5
68300357	35.7	60	1	15.5
68300367	36.7	60	1	15.5
68300377	37.7	60	1	15.5
68300387	38.7	60	1	15.5
68300397	39.7	60	1	16
68300407	40.7	60	1	16
68300417	41.7	60	1	16
68300427	42.7	60	1	16
68300437	43.7	60	1	16
68300447	44.7	80	2	24
68300467	46.7	80	2	24
68300487	48.7	80	2	24
68300497	49.7	80	2	24
68300507	50.7	80	2	24
68300527	52.7	80	2	24
68300547	54.7	90	2	26
68300567	56.7	90	2	26
68300587	58.7	90	2	26
68300597	59.7	90	2	26
68300607	60.7	90	2	26
68300627	62.7	90	2	26
68300647	64.7	100	2	26.5
68300667	66.7	100	2	26.5
68300687	68.7	100	2	26.5
68300697	69.7	100	2	26.5
68300707	70.7	100	2	26.5
68300727	72.7	100	2	26.5
68300747	74.7	100	2	26.5
68300767	76.7	100	2	26.5
68300787	78.7	100	2	26.5
68300807	80.7	100	2	26.5
68300817	81.7	122	2	27.5
68300837	83.7	122	2	27.5
68300857	85.7	122	2	27.5
68300877	87.7	122	2	27.5
68300897	89.7	122	2	27.5
68300917	91.7	122	2	27.5
68300937	93.7	122	2	27.5
68300957	95.7	122	2	27.5
68300977	97.7	122	2	27.5
68300997	99.7	122	2	27.5
68301017	101.7	140	2	32
68301037	103.7	140	2	32
68301057	105.7	140	2	32
68301077	107.7	140	2	32
68301097	109.7	140	2	32
68301117	111.7	140	2	32
68301137	113.7	140	2	32
68301157	115.7	140	2	32
68301177	117.7	140	2	32
68301197	119.7	140	2	32
68301217	121.7	140	2	32
68301237	123.7	140	2	32
68301257	125.7	140	2	32
68301277	127.7	140	2	32
68301297	129.7	140	2	32

Actuating screw

Id.No.	L
68030110	76.5
68030210	81
68030310	87.5
68030410	93
68030510	103
68030610	103
68030710	117
68030810	127
68030910	137
68031010	165
68031110	183

EM-B

Expanding mandrel
Manual or power operated

Expanding mandrels \varnothing 16 - 129.5 mm

- size 0 - 4
- large expansibility



Application/customer's benefit

- For turning, milling, grinding and gear cutting operations
- High flexibility by means of modular system
- High torque transmission and concentricity
- No axial movement of clamping sleeve during operation
- Clamping of very short workpieces on the front section of the sleeve possible

Technical features

- Large expansibility 1.5 mm in diameter
- Hand or power operated
- Flange mounting
- Very rigid design
- Tapped holes at the front face to mount axial stops
- Clamping sleeves are also available in vulcanized version

Standard equipment

Basic mandrel with draw bolt for power operation
Mounting bolts

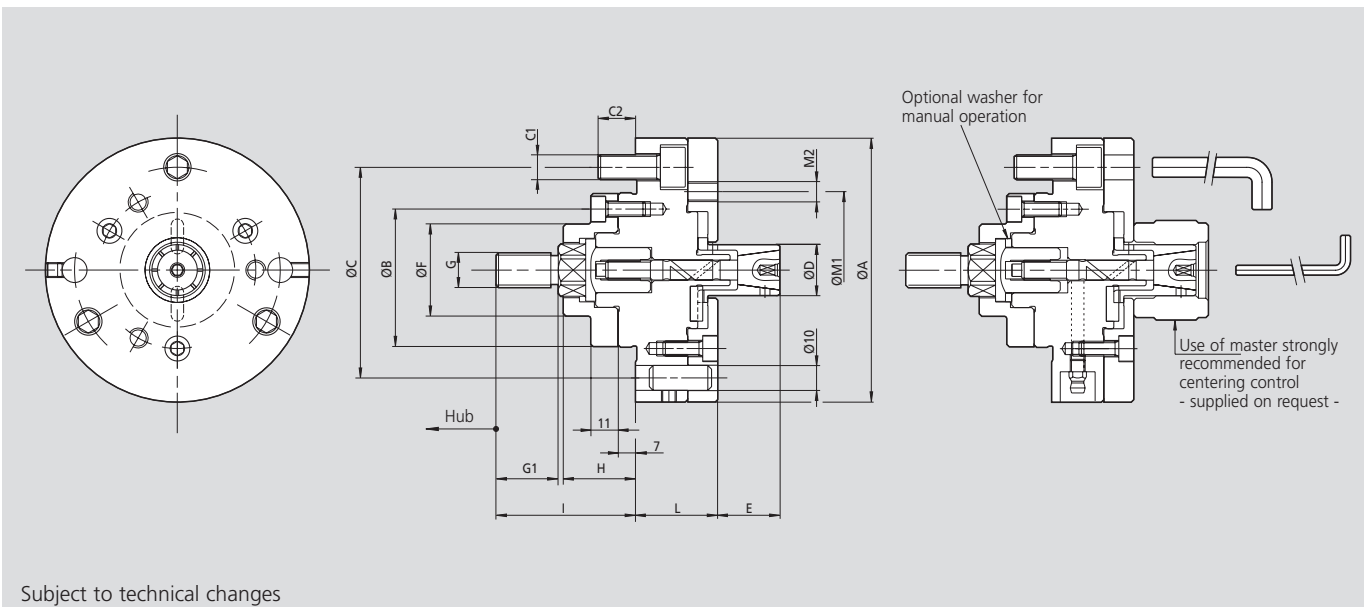

Subject to technical changes

SMW-Autoblok Type		EM-B 0	EM-B 1	EM-B 2	EM-B 3	EM-B 4
A	mm	106	106	106	125	180
B g5	mm	62	62	62	62	86
C	mm	82.6	82.6	82.6	82.6	133.4
C ₂	mm	16	16	16	16	15
E	mm	23	28	43	58	85
G	mm	M16	M16	M16	M16	M16
H	mm	29	29	29	29	36
L	mm	35	37	37	37	50
M2	mm	3 x M8	3 x M8	3 x M8	6 x M8	6 x M8
Sleeve expansion on \varnothing	mm	0.5	0.5	0.5	1	1.5
Max. axial force	kN	7	12	20	20	25

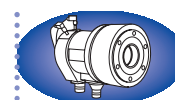

Page 177



Page 174

Adapters

ISO-A for
expanding mandrels

- mandrels EM-A and EM-B have cylindrical mounting
- adapters for ISO-A 702/1-DIN 55026 spindle noses

EM-A

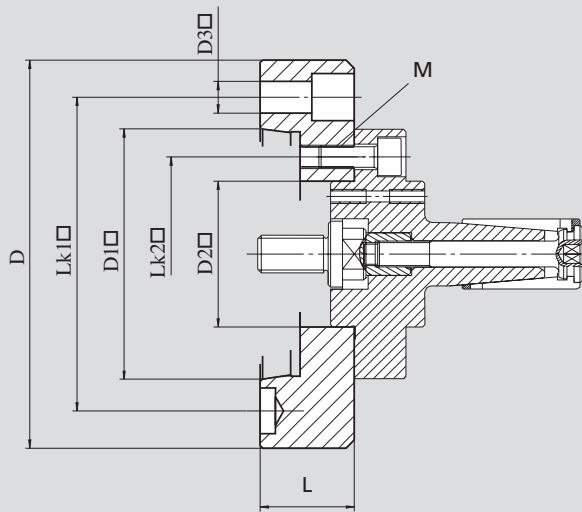

EM-B

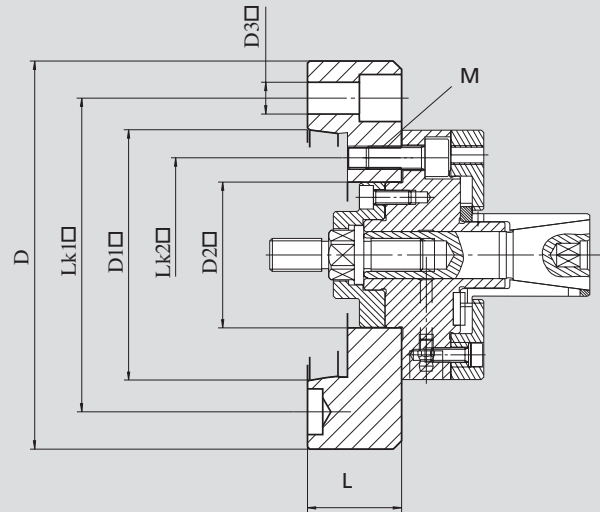

Subject to technical changes

Technical data

Adapter flange Id. No.		Spindle nose ISO	D	D1	D2	D3	LK1	LK2	L	M
24150100	mm	A5	127	82.563	62 ^{H6}	12	104.8	82.6	40	3 x M10
24150400	mm	A5	135	82.563	86 ^{H6}	12	104.8	104.8	40	3 x M10
24160100	mm	A6	165	106.375	62 ^{H6}	13.5	133.4	82.6	40	3 x M10
24160400	mm	A6	165	106.375	86 ^{H6}	13.5	133.4	104.8	40	3 x M10
24180100	mm	A8	210	139.719	62 ^{H6}	17	171.4	82.6	40	3 x M10
24180400	mm	A8	210	139.719	86 ^{H6}	17	171.4	104.8	40	3 x M10

Appropriate adapter flanges	EM-A	EM-B
24150100 ISO-A5		
24160100 ISO-A6	1 - 2 - 3 - 4 - 5 - 6	0 - 1 - 2 - 3
24180100 ISO-A8		
24150400 ISO-A5		
24160400 ISO-A6	7 - 8 - 9 - 10 - 11	4
24180400 ISO-A8		

Besides our standard range, we offer special solutions for your applications

Special mandrels

Example: Special expanding mandrel, sleeve design, on spindle and tailstock side for screw rotors

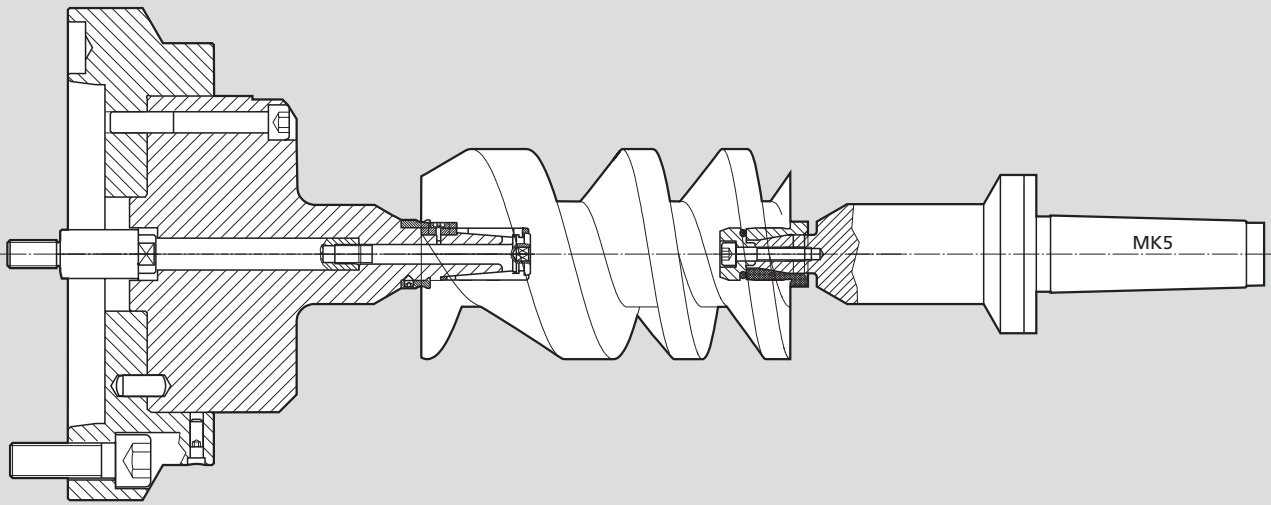

Example: Special mandrel segment design for tubes

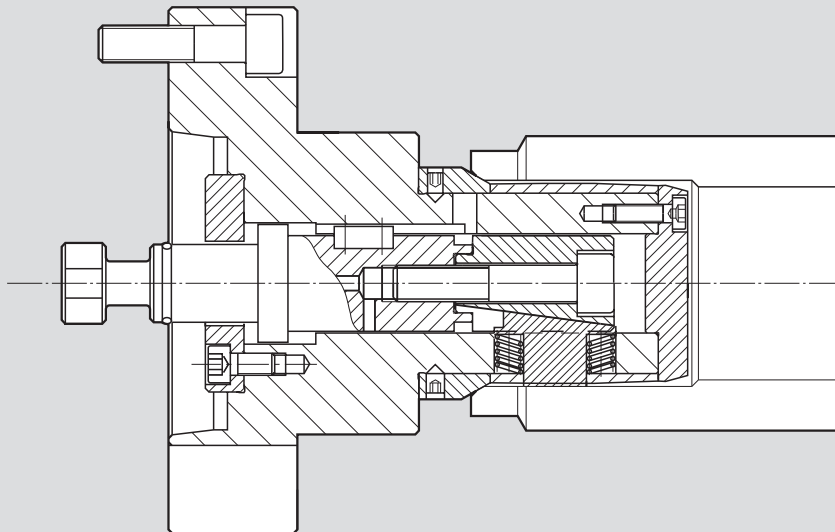

Example: Special expanding mandrel, double taper design with retractable stop, for clamping of stators

